



EN ISO 9001:2015  
**TUV NORD**

**WRAS**  
APPROVED PRODUCT

**EN**  
1388 - 2  
Manufactured According to

**EN**  
12976  
Manufactured According to

**CE**  
400380  
Manufactured According to

**GLASS ENAMEL**  
DIN 47533  
Manufactured According to

---

## **WATER HEATER TANK WARRANTY**

---

- > SAFETY INSTALLATION CONDITIONS
  - > SAFETY RECOMMENDATIONS FOR THE INSTALLATION AND MAINTENANCE OF THE WATER HEATER TANK
- 



Read carefully the safety installation manual, maintenance and warranty terms before installing the device, so as to avoid possible damage and to protect yourself from any risks.

---

## CONTENTS

---

### WATER HEATER TANK WARRANTY

THE COMPANY OFFERS THE FOLLOWING WARRANTY .....	3
WARRANTY TERMS .....	3
THE WARRANTY DOES NOT COVER.....	4

### SAFE INSTALLATION CONDITIONS

GENERAL INSTRUCTIONS.....	4
INSTALLATION & SPACE REQUIREMENTS FOR THE INSTALLATION .....	5
INSTALLATION PARTICULARITIES.....	5
WORKING CONDITIONS.....	5
PERSONNEL REQUIREMENTS .....	5
DEVICE TRANSPORTATION .....	5
RECOMMENDED SYSTEM INSPECTIONS.....	5
SYSTEM CHECK UPS .....	5

<b>DIMENSION &amp; EXPLANATORY BOARD (500L – 5000L).....</b>	<b>7</b>
--	----------

<b>DIMENSION &amp; EXPLANATORY BOARD (7000L – 9000L).....</b>	<b>8</b>
---	----------

<b>TRANSFERRING THE HOT WATER TANK.....</b>	<b>9</b>
---	----------

<b>POSITIONING THE HOT WATER TANK.....</b>	<b>9</b>
--	----------

<b>LIFTING INSTRUCTIONS.....</b>	<b>10</b>
----------------------------------	-----------

<b>INSULATION PLACEMENT &amp; REMOVAL.....</b>	<b>11</b>
--	-----------

<b>EXCHANGER REMOVAL.....</b>	<b>12</b>
-------------------------------	-----------

### INITIAL START OF HOT WATER TANK

LEAK TEST .....	12
-----------------	----

SAFETY RELIEF VALVE.....	12
--------------------------	----

OPERATING TIPS.....	12
---------------------	----

SHUTDOWN TIPS.....	13
--------------------	----

<b>MAINTENANCE.....</b>	<b>13</b>
-------------------------	-----------

<b>CLEANING THE HOT WATER TANK.....</b>	<b>14</b>
---	-----------

<b>MAGNESIUM ANODE CHECK.....</b>	<b>14</b>
-----------------------------------	-----------

<b>MAINTENANCE BOOK.....</b>	<b>15</b>
------------------------------	-----------

### TEXT MARK EXPLANATIONS:

---



SAFETY TIPS



LEGAL NOTE



IMPORTANT INFORMATION

# WATER HEATER TANK WARRANTY

---

## THE COMPANY OFFERS THE FOLLOWING WARRANTY:

> For the heat tank five (5) years warranty.

## FURTHERMORE, THE WARRANTY IS VALID ONLY WHEN THE FOLLOWING TERMS ARE SATISFIED:

1. The heat tank must be installed and maintained by specified and certified personnel.
2. For epoxy coated steel tank, the magnesium bar of the heat tank, must necessarily be checked every year and it must be replaced instantly if it has been outworn to a percentage above 50% or it has been covered by the accumulation of salts.
3. The standard of the water quality used by the system should not be lower than the potable (page 4 table)
4. The tank should be grounded.
5. The water supply pressure should not exceed 10 bars, otherwise a pressure reducer should be installed.
6. System temperature and pressure should not exceed the specifications as indicated in the device's technical manual.
7. The tank should always have safety valves that will protect the system from the maximum temperature and maximum operating pressure. For the proper operation of the heat tank, it is necessary to check the safety valves and in case of malfunction must be replaced .
8. The area where the system is to be installed must have a functional water drainage on the floor.
9. The user must take all appropriate measures to exclude the overheating phenomenon.
10. The hydraulic connections to the tank must be such as to exclude the phenomenon of electrolysis.
11. The tank should not be damaged by a drop or a hit during transport or installation.
12. Maintenance of the heat tank must be in accordance with the maintenance schedule which the installer has design.
13. The installer and maintainer should record the tasks and the reason why they were called in the maintenance book. This record file is a key element of the warranty and should be made available on request.
14. All repairs or maintenance must be carried out using quality spare parts which are specific indicated in the device's maintenance book. Under no circumstances should you exercise any welding on the tank's metal structure. You risk to deteriorate or destroy the tank.
15. The installation must meet the conditions described in the installation manual which is an integral part of the warranty.
16. The tank does not feature a heating element. Upon request by the user a heating element may be placed in any of the free sockets indicated only by a certified installer and a certified electrician. Only special heating element shall be placed in the tank. The certified installer is responsible to indicate the appropriate position and type of the heating element – always guided by the instructions provided by the heating element manufacturer. The constant and unreasonable use of the heating element may cause damage to the tank and will set it beyond warranty.

### CAUTION!



#### Safety tips

The active part of the heating element shall not be inside the socket (tank's coupling or neck). Instead it shall be as closer as possible to the center of the tank, so as the heated water can be naturally alternated over the heating element's surface.

The tank shall always be placed on a totally flat surface (without any inclination) so that no air is captured in the couplings or any other part, especially if this part is close to the heating element.

The heating element shall always be totally covered by water.

### ATTENTION!



**Very poor water quality at the water outlet can result in salt formation and salts may block the safety valve. In this case, the tank remains unprotected against very high temperatures above 90°C and high pressure (greater than 10 bars).**



## THE WARRANTY DOES NOT COVER:

- > For epoxy coated steel tank, the magnesium rod in the tank.
- > Damage to the heating element.
- > Damage to safety valves (if are included in the tank's packaging) of the tank, by excessive concentration of salts or external bodies.
- > Tank damage due to excessive pressure of the water supply network.
- > Damage of the tank caused by overheating.
- > Damage caused by unauthorised third party intervention.
- > Damage caused by improper maintenance.
- > Damage caused by extreme operating conditions and extrinsic factors (*vandalism, fire, etc.*).
- > The sealing flange

## NOTE:

*In the event of a breakdown, the workshop's fees and transport costs are borne by the customer in any case. The manufacturer reserves the right to change the terms without notice.*

WATER SPECIFICATIONS TABLE

ELEMENT	PRICES
pH	7-9
Total hardness	6-15° dH
Chlorides	< 100 mg/l
Free chlorine	< 0,5 mg/l
Sulphates	< 80 mg/l
Conductance	< 650 mS/cm 25°C

## SAFE INSTALLATION CONDITIONS

This is an integral part of the warranty to which it refers. It is not an installation guide. It refers to the appropriate conditions for a safe and right installation.

### GENERAL INSTRUCTIONS

1. This manual is an essential and indispensable part of this device. It has to be carefully kept and always accompany the device.
2. Please read the instructions and warnings carefully. They contain crucial information concerning the safe installation, operation and maintenance of this new device.
3. The responsibility of installation lies with the buyer and has to be performed by an authorized specialist.
4. Using the device for reasons other than those specified in the manual is strictly prohibited. The manufacturer shall not be held liable for any damage caused by improper or unjustifiable use or by failure to comply with the instructions in the manual.
5. Installation, maintenance, and other special work on the device have to be performed by a specialist, always in compliance with existing instructions provided by the manufacturer.
6. Faulty installation may cause personal injury or damage your property. The manufacturer shall not be held liable for such damage.
7. Keep all packaging materials (*clips, plastic bags, polystyrene foam*) out of reach of children, as hazards may occur.

8. All repairs must be performed exclusively by an authorized specialist, using only the appropriate parts. Failing to comply with the instructions above may affect your safety and relieves the manufacturer of all responsibility.

### CAUTION!



*The installation must comply with local regulations, concerning hydraulic and electrical installations. Removing the packaging must be done on site, in order to protect the device from being damaged.*

### RISK TO HEALTH



Improper installation work can contaminate the potable water.

- Install the hot water tank hygienically and thoroughly and in accordance with current standards
- Rinse the hot water tank and piping thoroughly with potable water.

Install and equip the potable water pipes according to your country's applicable regulations and instructions.

## INSTALLATION & SPACE REQUIREMENTS FOR THE INSTALLATION



Before installing the water heater tank, you have to choose the right location carefully and check the surface, to ensure it can bear the device's weight. The water heater tank must be installed on a flat surface with adequate bearing capacity.

### INSTALLATION PARTICULARITIES

In case the chosen surface is not compatible with the standard equipment provided, another kind of equipment will have to be used. Responsibility for choosing the equipment lies solely on the installation expert and not on the manufacturer. It is up to the installation expert, whether they will suggest using another kind of equipment to the customer, to which the customer has to have agreed upon prior to the installation.

### WORKING CONDITIONS

Keep the installation area clean and free of objects that may hinder the installation process. Do not allow other people, apart from the installation expert, to get near the tools, as well as the installation location. Use only parts that are compatible with the water heater you bought. The use of other parts or unsuitable tools may cause accidents or pose other hazards.

### PERSONNEL REQUIREMENTS

The installation of water heaters has to be performed exclusively by authorized installation experts (*technicians*). Always wear protective glasses, suitable working attire, protective shoes and helmet. In hazardous locations, all protection measures must be taken and only special equipment must be used.

### DEVICE TRANSPORTATION:

#### Transportation and handling of the tank

Abrupt movements must be avoided during the transportation of the tank, as they may result in fall and damage.

- You must be extremely careful while lifting the tank and always take precautions, in order to avoid possible accidents, injuries and other hazards.
- To avoid damaging the tank, do not remove the packaging, until it reaches the installation location.
- Do not place the tank on hard or uneven surfaces.

## RECOMMENDED SYSTEM INSPECTIONS



### ATTENTION!

*BECAUSE SYSTEM MAINTENANCE AND CONTROL ARE DEPENDING FROM EVERY LOCAL CLIMATE DATA, WATER QUALITY AND THE OWNERS USAGE THE MAINTENANCE FREQUENCY IS PART OF THE AGREEMENT BETWEEN THE SYSTEM OWNER AND THE MAINTAINER INSTALLATION AND SYSTEM CONTROLS MUST ALWAYS BE PERFORMED BY AUTHORIZED SPECIALISTS. THE DATA OF MAINTENANCE SHOULD BE ALWAYS RECORDED IN THE MAINTENANCE BOOK FROM THE INSTALLER.*

### SYSTEM CHECK UPS

- Annually – preferably before the start of the high usage period to ensure that the heater operates properly and all the parts are in good working condition.
- Maintenance periods are determined upon delivery of the heater. During maintenance, you have to make sure that the following parts work properly:
  - Pressure reducer
  - Heat exchanger circuit
  - All joints and pipes for leaks
  - For epoxy coated steel tank, magnesium anodes
  - Pipes insulation
  - Safety valves
  - Sealing flange

### ATTENTION!



*IN CASE THAT ALL THE NECESSARY MEASURES ARE NOT TAKEN AND THE SYSTEM IS OVERHEATED, EXCEEDING THE SAFETY TEMPERATURE OF 85°C, THEN THE SYSTEM IS OUT OF THE WARRANTY FOR STAINLESS STEEL TANK, 95°C.*

### Devise maintenance

The water heater tank maintenance must be performed according to the plan determined upon delivery. The maintenance book must always be completed after the maintenance man's visit.

### Dismantling and Disposal

All the device's materials have to be properly disposed of, according to existing legislation. Uninstalling, transportation and other costs must be paid by the owner.



*During of the constant evolution and improvement of the products and services, the manufacturer reserves the right to change or modify the information or of the specifications mentioned herein manual without prior notice or other obligation*

# DIMENSION & EXPLANATORY BOARD (500L – 5000L)

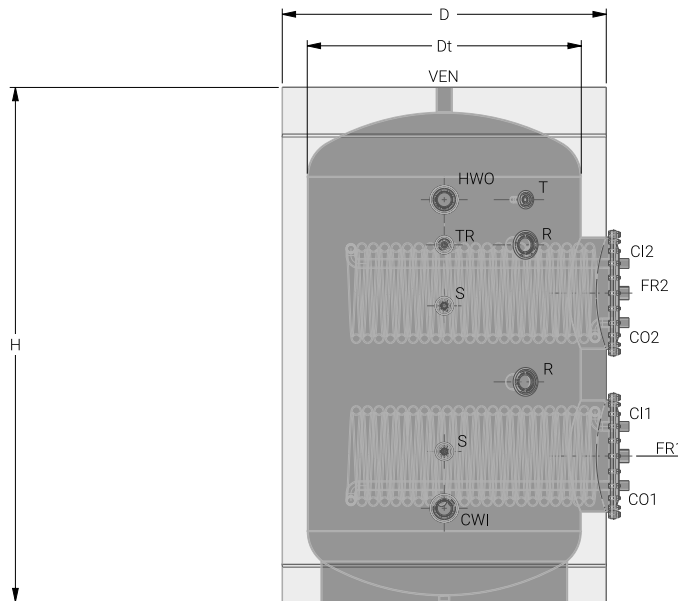

TYPE		BLE- 500	BLE - 750	BLE - 1000
	Tank capacity without coil (liter)	478	741	863
	Tank capacity with 1 coil 2,2m <sup>2</sup> (liter)	464,78	-	-
	Tank capacity with 2 coils 2,2m <sup>2</sup> (liter)	451,56	-	-
	Tank capacity with 1 coil 3,2m <sup>2</sup> (liter)	-	721,17	843,17
	Tank capacity with 2 coils 3,2m <sup>2</sup> (liter)	-	701,34	823,34
	Tank capacity with 1 coil 5,4m <sup>2</sup> (liter)	-	-	-
	Tank capacity with 2 coils 5,4m <sup>2</sup> (liter)	-	-	-
	Tank capacity with 1 coil 3,2m <sup>2</sup> & 1 coil 5,4m <sup>2</sup> (liter)	-	-	-
	Coil 2,2m <sup>2</sup> capacity (liter)	13,22	-	-
	Coil 3,2m <sup>2</sup> capacity (liter)	-	19,83	19,83
	Coil 5,4m <sup>2</sup> capacity (liter)	-	-	-
	No.of Flanges/int.Diameter (mm)/Ext.Diameter (mm)	2 / Ø420 / Ø508		
R	Recirculation	1"		
CWI	Cold Water Inlet	1 1/2"		
HWO	Hot Water Outlet	1 1/2"		
T	Thermometer	1/2"		
TR	Thermostat	1/2"		
S	Sensor	1 1/2"		
F1,F2	Free Outlets	1 1/2"		
H	Total Height	1750	1780	2020
D	External Diameter (mm)	840	1000	1000
Dt	Internal Diameter (mm)	640	800	800
C1,C2	Coil Inlet 1, Coil Inlet 2	1"		
CO1,CO2	Coil Outlet 1, Coil Outlet 2	1"		
	Tilt Height (mm)	1917	2040	2230
	Coil 2,2m <sup>2</sup> Weight (kg)	47	-	-
	Coil 3,2m <sup>2</sup> Weight (kg)	-	60	
	Coil 5,4m <sup>2</sup> Weight (kg)	-	-	-
	Total Weight Without Coil (kg)	139	209	229

FLOOR STANDING BOILER 500-5000L WITH TWO REMOVABLE COILS

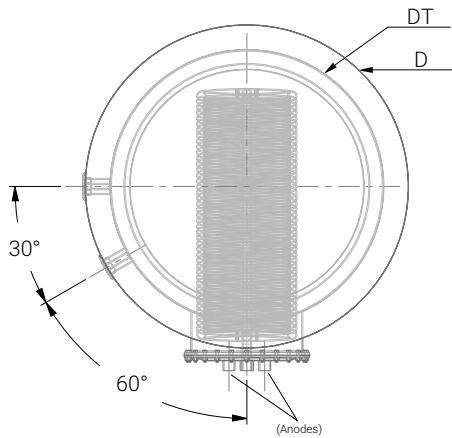

**Material:** Epoxy coated steel sheet / Stainless steel sheet

**Welding:** Automatic Metal Welding

**Protection Coating for epoxy coated steel tank:** High Quality glass until 500lt, epoxy resin from 750Lt till 9000 Lt and protection anode

**Maximum Working Pressure:** 10 bar

**Maximum Operating Temperature:** 85°C for stainless steel tank, 95°C

**Coil:** Epoxy coated steel tube / Stainless steel tube

**Maximum Coil Test Pressure:** 25 bar

**Insulation:** Removable Soft Polyurethane foam of 100 mm thickness

**Electric Resistance:** Upon Request

**Flange Diameter (Anode–Cleaning Flange):** Ø508 mm

**External Cover:** Soft pvc, color of your choice

BLE- 1500	BLE - 2000	BLE - 3000	BLE - 4000	BLE - 5000
1680	1980	3390	3910	4920
-	-	-	-	-
-	-	-	-	-
1660,17	1960,17	3355,98	-	-
1640,34	1940,34	3321,96	-	-
1646,95	1946,95	3333,3	3853,3	4863,3
1613,9	1913,9	3276,6	3796,6	4806,6
1627,12	1927,12	3299,28	-	-
-	-	-	-	-
19,83	19,83	34,02	-	-
33,05	33,05	56,7		
2 / Ø420 / Ø508		2 / Ø508 / Ø620		
2"		3"		
1/2"				
1 1/2"				
2100	2120	2330	2379	2850
1300	1400	1700	1800	1800
1100	1200	1500	1600	1600
1"		1 1/2"		
2457	2517	2884	2984	3360
-	-	-	-	-
68		90		
85		130		
420	490	765	865	930

# DIMENSION & EXPLANATORY BOARD (7000L – 9000L)

## FLOOR STANDING BOILER 7000-9000L WITH THREE REMOVABLE COILS

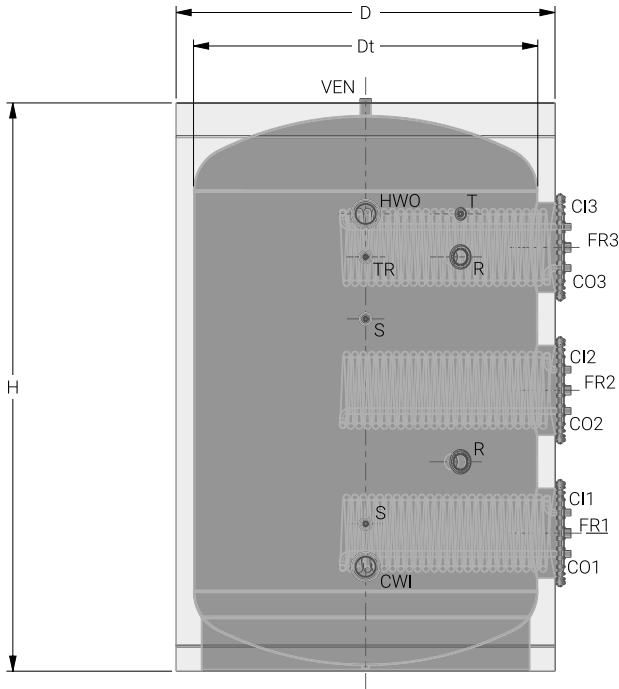

**Material:** Epoxy coated steel sheet / Stainless steel sheet

**Welding:** Automatic Metal Welding

**Protection Coating for epoxy coated steel tank:** Epoxy resin, Enamel and protection Anode

**Maximum Working Pressure:** 10 bar

**Maximum Operating Temperature:** 85°C for stainless steel tank, 95°C

**Coil:** Epoxy coated steel tube / Stainless steel tube

**Maximum Coil Test Pressure:** 25 bar

**Insulation:** Removable Soft Polyurethane foam of 100 mm thickness

**Electric Resistance:** Upon Request

**Flange Diameter (Anode–Cleaning Flange):** Ø620mm

**External Cover:** Soft pvc, color of your choice

TYPE		BLE - 7000	BLE - 9000
	Tank capacity without coil (liter)	7150	9040
	Tank capacity with 1 coil 7,8m <sup>2</sup> (liter)	7070,62	8960,62
	Tank capacity with 2 coils 7,8m <sup>2</sup> (liter)	6991,24	8881,24
	Tank capacity with 3 coils 7,8m <sup>2</sup> (liter)	6911,86	8801,86
	Coil 7,8m <sup>2</sup> capacity (liter)	79,38	
	No.of Flanges/Int.Diameter (mm)/Ext.Diameter (mm)	2 / Ø508 / Ø620	
R	Recirculation	3"	
CWI	Cold Water Inlet	4"	
HWO	Hot Water Outlet	4"	
T	Thermometer	1/2"	
TR	Thermostat	1/2"	
S	Sensors	1 1/2"	
F1, F2, F3	Free Outlets	1 1/2"	
H	Total Height	3261	3340
D	External Diameter (mm)	2000	2200
Dt	Internal Diameter (mm)	1800	2000
CI1, CI2, CI3	Coil Inlet 1, Coil Inlet 2, Coil Inlet 3	1 1/2"	
CO1, CO2, CO3	Coil Outlet 1, Coil Outlet 2, Coil Outlet 3	1 1/2"	
	Tilt Height (mm)	3825	3999
	Coil 7,8m <sup>2</sup> Weight (kg)	154	
	Total Weight of the Ready Product Without Coil (kg)	1400	1800



# TRANSFERRING THE HOT WATER TANK

---

The hot water tank should be transferred to the area where it will be placed on its special transfer pallet. Transfer and placement should be carried out by specialised personnel with the appropriate equipment. The area where the tank will be installed should have the required specifications for a boiler room.

## USER NOTE



For tank installation and maintenance, the required free space around and above the tank should be ensured during planning, so as to allow carrying out the required procedures.

## CAUTION!



**RISK OF INJURY** by not securing the tank adequately during transport.

- Use only suitable means for transportation.
- Secure the transported load against falling.

## CAUTION!



**RISK OF INJURY** from carrying heavy loads.

- Lifting and transfer should be always carried out by specialised persons.

## USER NOTE



Where possible, transport the hot water tank fully packed to the installation room. This ensures protection during transportation.

# POSITIONING THE HOT WATER TANK

---

The hot water tank is designed for vertical or horizontal installation (depending on its type) and can be installed in accordance with its dimensions. The floor has to be level and durable. Please see in the next page the guide for the proper placement of a vertical tank.

## CAUTION!



**BOILER DAMAGE** from frost.

- The installation area must be dry and protected from freezing.

## CAUTION!



**BOILER DAMAGE** from corrosion.

- Use the hot water tank in closed loop systems only.
- Do not use open expansion vessels.



Open the package carefully.  
Do not use sharp tools, risk of shell and insulation injury.



# LIFTING INSTRUCTIONS (OVER 5000L )

01 A

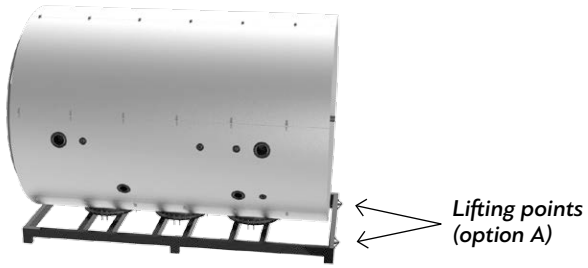

01 B

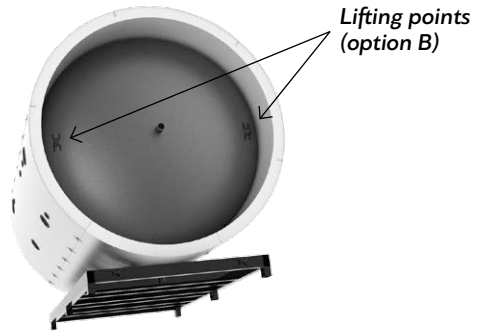

02

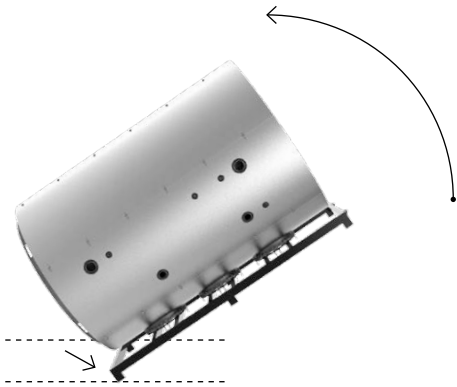

When lifting the tank, the bottom part of the metal transportation pallet shall ALWAYS touch the ground, as shown in the pictures

03



04

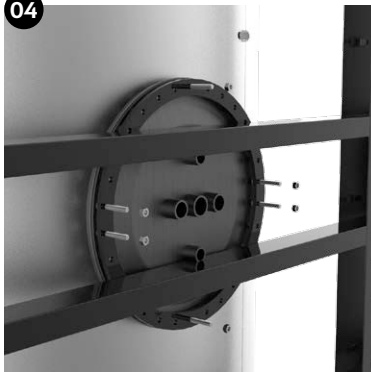

05

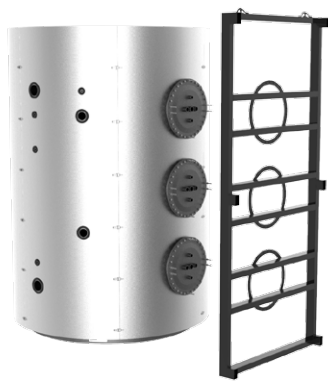

06

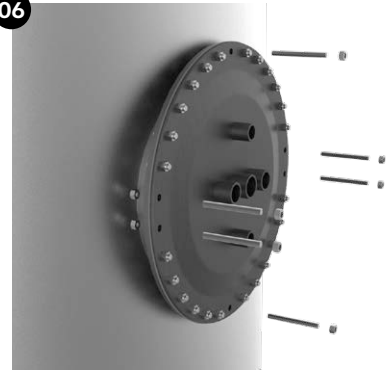

07



08



09



# INSULATION PLACEMENT & REMOVAL

01

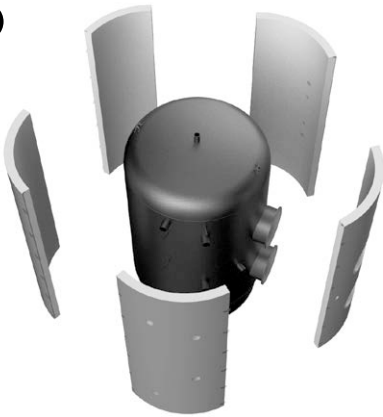

When removing and replacing the insulating shell, please follow the order as specified in the following pictures. The part with the smallest size shall be placed last.

02



03



04



05



06

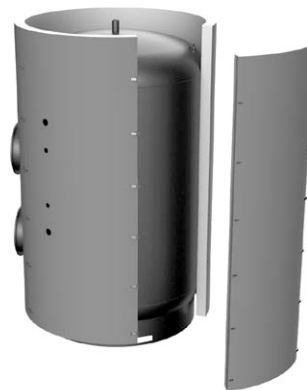

07



08

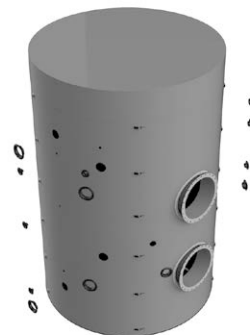

## EXCHANGER REMOVAL

---

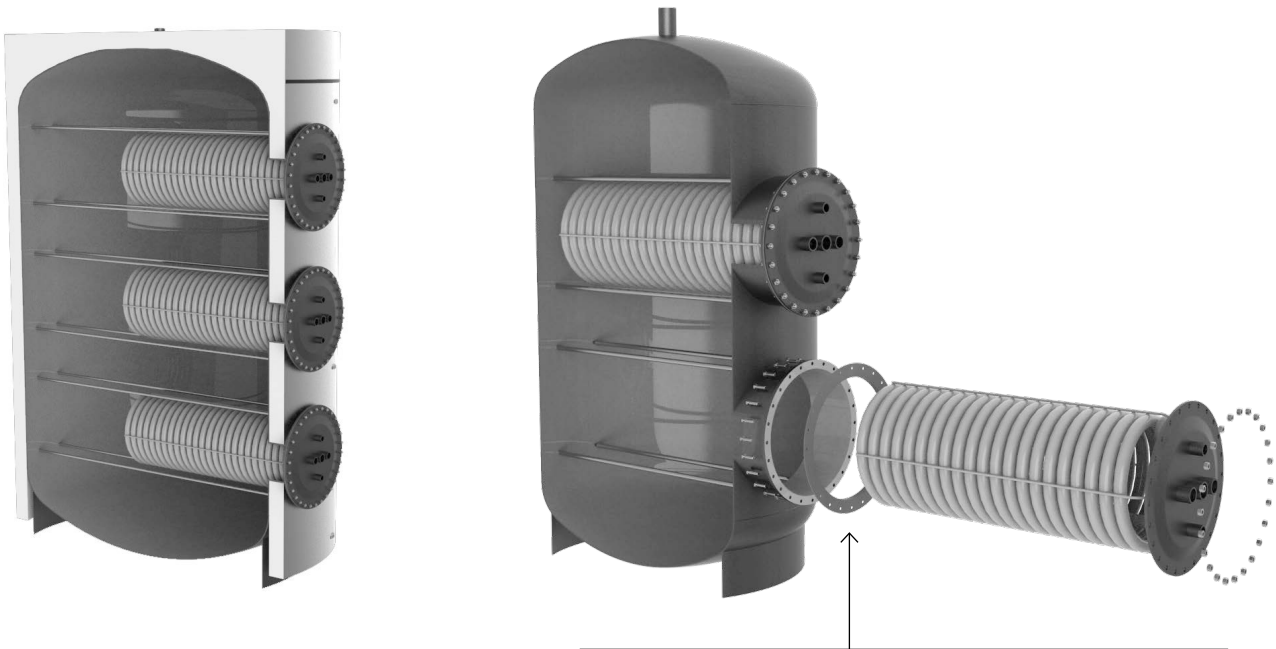

During the maintenance process when inserting or extracting the heat exchanger (coil) from the tank you must never drag or let it come in contact with the inner surface of the flange hole.

## INITIAL START OF HOT WATER TANK

---

Before putting the hot water tank into operation, check its impermeability to avoid leaks during operation.

- Vent the hot water tank by opening the vent/bleed valve or the highest faucet.
- Before heating up, check that the boiler, the hot water tank and piping are completely filled with water by opening the vent/bleed valve.
- Check all connections, piping and the cleaning port for leaks.

### LEAK TEST

Check all connections, the cleaning port, and the electrical anode for leaks.

### USER NOTE

Carry out the hot water tank leak test with potable water only. The maximum test pressure must not exceed 10 bars.



### SAFETY RELIEF VALVE

(supplied by the customer)



- Place a sign with the following indication on the safety relief valve: “Don’t close the blow-off line. Water leakage may occur during heating for security reasons.”
- The blow-off line cross-section should be at least equal to the output cross-section of the safety relief valve.
- Check regularly the operational readiness of the safety relief valve with manual test.

### OPERATING TIPS

Inform the facility owner that

- the relief valve blow-off line always needs to be kept clear.
- the proper functioning of the relief valve should be checked at regular intervals with manual test.

- the local heating contractor should be notified if the thermal safety cut-out on the boiler is triggered repeatedly.

## SHUTDOWN TIPS

In the case of long periods of absence of the facility owner we recommend the following:

- Keep the hot water tank in operation.

If you ever need to shut down the hot water tank, when you start using it again, observe the hygiene and potable water requirements applicable in your country.

## CAUTION!



### BOILER DAMAGE

*The hot water tank can be permanently damaged by excessive pressure if the safety relief valve is blocked.*

- Always keep the blow-off line of the safety relief valve open.

## CAUTION!



### BOILER DAMAGE

*If the hot water tank ever has to remain empty for several days, signs of corrosion may appear due to residual moisture.*

- Thoroughly dry the inside of the tank (e.g. with hot air) and keep the cleaning port cover open.

# MAINTENANCE

Checking and cleaning of the hot water tank by an expert at least every two years is generally recommended. Please inform the facility owner accordingly. Shorter checking and cleaning intervals should be chosen in case of bad quality water (hard to very hard water) together with high operating temperatures.

Preparing the hot water tank for cleaning

- Disconnect the power supply of the heating system and disconnect all electrical power supply to the resistor, if present in the tank.
- Empty the hot water tank by closing the fresh water supply valve and drain the tank. For ventilation, open the vent/bleed valve or the highest faucet.
- Remove the casing lid and the thermal insulating element from the hot water tank.
- Unscrew the screws from the cleaning port cover.
- Remove the cleaning port cover.
- Unscrew the hex screws; remove the cleaning port gasket and the sealing gasket.

## USER NOTE



The sealing gasket feature must have at least the same technical specification with the one provided by the tank producer.

## CAUTION!



**BOILER DAMAGE due to unsatisfactory cleaning and maintenance.**

- Carry out cleaning and maintenance of the hot water tank at least every two years.
- Immediately restore all faults to prevent damages!

## RECOMMENDATION

During the system's use there might be gathered precipitates, other materials and Biofilm in the tank. This is mainly due to the bad water quality, to the water supply network, to the water pipes and to the water heating exchanger inside the tank. The for mentioned phenomenon might deteriorate the water quality so it is recommended apart from the scheduled tank cleaning also a filter placement to the water inlet from the water network.



During maintenance, manhole sealing and heat exchanger flange should be removed.

# CLEANING THE HOT WATER TANK

---

Check the hot water tank interior for scale (salt) deposits. If there are scale deposits inside the hot water tank, these should be removed. You can increase the cleaning effect by heating up the empty hot tank; the thermo-shock effect releases scale deposits more easily from the heat exchanger coil. Remove the residues with a wet & dry vacuum cleaner with plastic suction tube. If the deposits inside the hot water tank are too hard, you can remove them with chemical cleaning. It is recommended to employ a specialised technical company for the chemical cleaning.

## CAUTION!



### DAMAGE OF THE INSTALLATION from damaged surface finish.

- Never use hard objects or objects with sharp edges to clean the interior walls of the hot water tank.
- If you observe or notice damage or destruction of the tank's finish, you should contact with the supplier from which it was bought to carry out the planned actions

## CAUTION!



*Under no circumstances should you exercise any welding on the tank's metal structure. You risk to deteriorate or destroy the tank. If there is such a need it should be effected only by specialized personnel.*

## CAUTION



### PREVENT LEGIONELLA RISK IN THE HOT WATER TANK

*The primary method used to control the risk from Legionella is water temperature control.  
The water temperature at the bottom of the tank shall at least once per week, depending on the use and the water quality, reach or overpass 60 C for at least 30 minutes. This period shall be adjusted by the installer.*

# MAGNESIUM ANODE CHECK (FOR EPOXY COATED STEEL TANK)

---

The magnesium anode is a protective anode, which is consumed during the operation of the hot water tank. The magnesium anode should be visually checked at least every year and replaced in case it is necessary. During magnesium anode check the elastic flange shall also be checked for any damages and it shall be replaced if necessary.

- Check the magnesium anode for decay. Replace the magnesium anode if its diameter has been reduced by more than 50%.

## USER NOTE



Do not allow the contact of the magnesium anode with oil or other lubricants. Make sure that the rod is clean.

# MAINTENANCE BOOK

---

DATE OF PURCHASE: ..... OWNER DATA: .....

RETAILER: .....

INSTALLER INFORMATION: .....

MAINTENANCE DATE	MAINTAINER INFORMATION	REASON OF VISIT	EXECUTED OPERATIONS	SPARE PARTS USED

